

GENERAL INFORMATION:

MiraTEC Treated Exterior Composite Barn Trim is an engineered wood composite barn trim designed for use in exterior shed or barn applications where a nonstructural smooth or wood grain textured blemish-free trim product is desired. MiraTEC barn trim resists moisture, rot and termites.

CUTTING:

Use a fine-tooth hand saw or power saw with a combination blade. Cut into the exposed face of the material. Carbide-tipped blades are recommended.

FASTENING REQUIREMENTS:

MiraTEC barn trim is a nonstructural decorative trim product and should not be used where structural lumber properties are required. MiraTEC barn trim is designed to be applied to structural framing, sheathing and other materials.

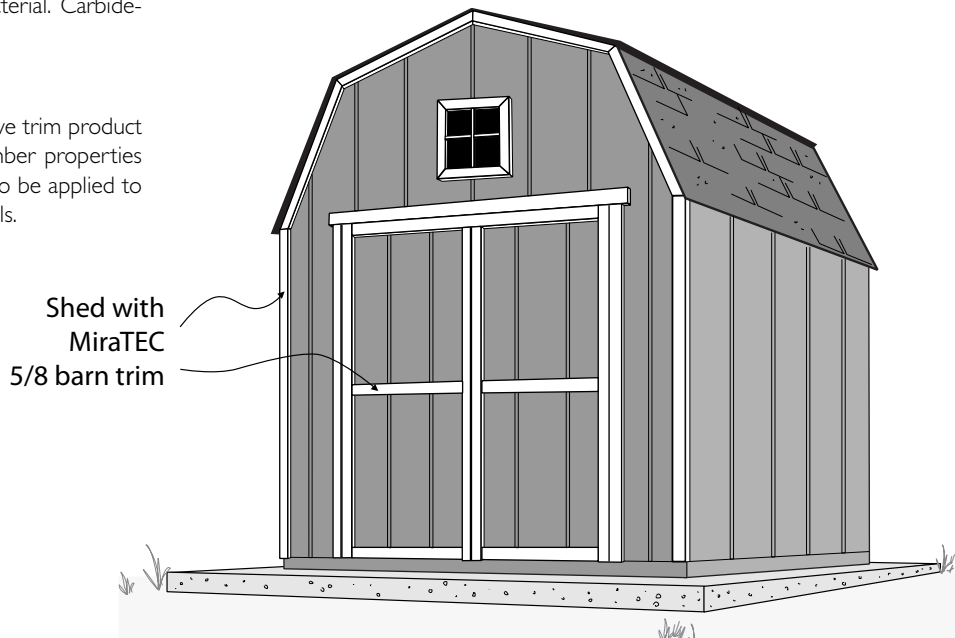

Note: Nail at least 1/2" from edge. Do not edge nail or nail into the cut end of MiraTEC barn trim. For a fascia application, MiraTEC barn trim must be double nailed and fastened a maximum of 24" on center. For all other horizontal applications, double nail 16" on center, falling on the studs.

Fasten MiraTEC barn trim from one end to the other end.

DO NOT nail toward the center from both ends.

CORRECT

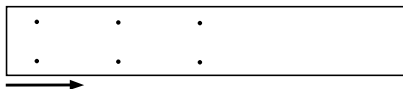

INCORRECT

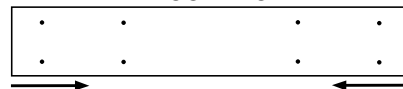

BUTT JOINTS:

All joints must fall over a framing member. MiraTEC barn trim can be mitered, scarfed, or beveled as required. For runs less than 30 feet in length, butt joints should lightly touch. For runs over 30 feet in length, space all butt and scarf joints 1/8" apart and apply sealant into the full depth of the 1/8" joint. Double nail all joints on both sides as noted in the diagram.

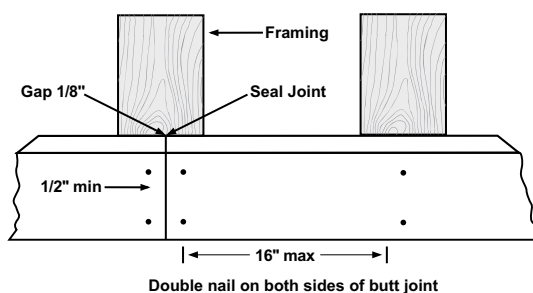

Double nail on both sides of butt joint

FASTENERS:

Use fasteners which are equal in performance (such as nail withdrawal, bending strength and corrosion resistance) to 6d or 8d nails long enough to penetrate 1 ¼" into structural wood studs or studs and sheathing material. Use nails with corrosive resistance equivalent to hotdipped galvanized nails. For installations near oceans, large bodies of water or in high humidity climates, CMI recommends using stainless steel fasteners on MiraTEC barn trim. For these installations, do not use electro-galvanized fasteners, due to poor long term rust resistance.

Power or pneumatic nailing systems may be used. Visit www.miratectrim.com for information on air pressure settings on a variety of pneumatic nailers. Tapered or bugle head fasteners are permitted when the heads are properly sealed from moisture.

Nail heads, or any other dents, can be filled with exterior grade spackling putty specifically designed for filling nail holes. Allow putty to dry, sand smooth with 100 grit sandpaper and spot prime before painting. Over time, spackling putty may need to be replaced or touched up. For the best aesthetic appearance when using the smooth side of MiraTEC barn trim, additional work is required. The nails should be set flush or slightly countersunk (not to exceed 1/8"). Then apply the spackling putty as outlined above. Reapply the putty as needed for desired appearance.

Use a nail that is appropriate to the style of construction. Do not use staples, braids, or t-nails.

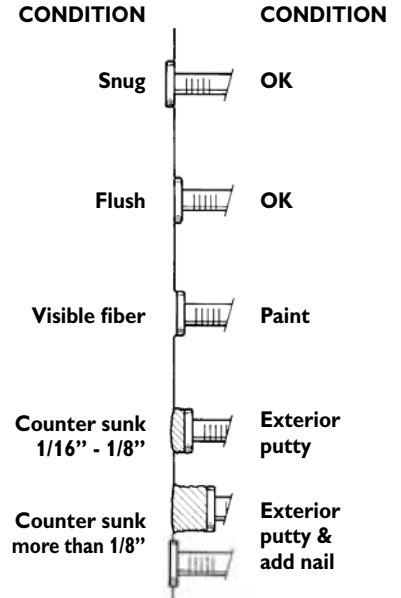

FLASHING AND MOISTURE CONTROL:

The structure on which MiraTEC barn trim is applied should be well ventilated and dry. Do not apply MiraTEC barn trim over wet sheathing, or any closer than 6" to finished grade or final landscaping. As with all wood products, MiraTEC barn trim should not come in direct contact with masonry or concrete. Properly flash and space at least 1/2" from any concrete flatwork. At foundations, the product should be separated from the masonry by metal flashing, polyethylene film, 30 lb. felt or a 1/4" to 1/2" air space using masonry standoffs. In all applications, MiraTEC barn trim should not be allowed to stand in water. For applications near rooflines, such as dormers, the MiraTEC barn trim should be installed with a minimum of 1" clearance between the roofing and the bottom edge of MiraTEC barn trim. At the junction of the roofing material and vertical surfaces, flashing is required per the roofing manufacturers' application requirements.

Seal the trim applications to prevent water intrusion. Do not allow water to stand on or leak behind any MiraTEC barn trim. MiraTEC barn trim used in a horizontal application, including window and door headers, must be properly flashed in accordance with the siding manufacturers', window manufacturers', or door manufacturers' application requirements.

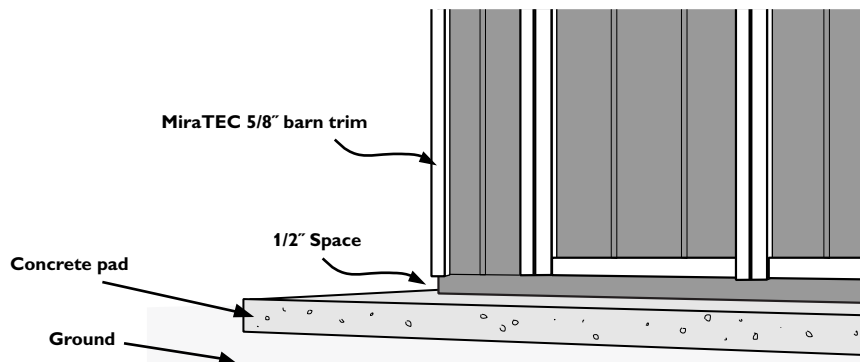
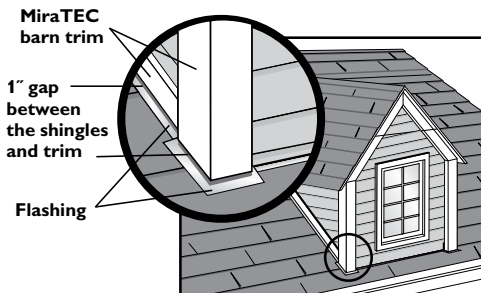
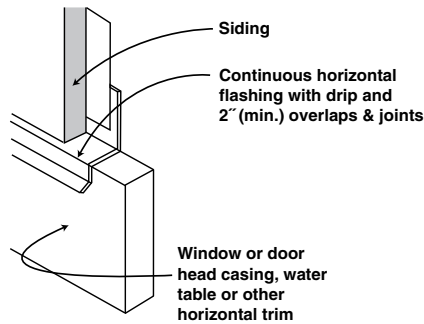

ADHESIVES:

Glues or adhesives can be used on MiraTEC barn trim such as on mitered joints for outside corners or column wraps. Use a high quality exterior grade yellow carpenters glue or a high quality polyurethane adhesive.

SEALANT:

Sealant is required at butt joints and where MiraTEC barn trim abuts siding, windows, doors or other materials. Use only exterior quality sealant that remains flexible over time. Do not use hard-setting caulk. Apply caulk according to the manufacturer's written instructions. CMI recommends caulks and sealants that meet ASTM C920.

SURFACE PREPARATION:

The surface to be painted must be free of dust, dirt, mildew and other foreign materials before painting. Wash with water and a mild detergent to remove dust and dirt. Allow the surface to dry before painting. If mildew is present, contact a paint supply store for recommended methods of removing and controlling mildew.

GENERAL INFORMATION:

Paint performance is dependent upon the quality and quantity of paint applied, and the conditions under which it is applied. Low quality paint and/or thinly applied paint tends to last for a relatively short time, resulting in discoloration, premature fading, inadequate substrate protection, and frequent repainting - sometimes as often as every one or two years. Top quality paint, applied in sufficient quantity, will provide the best performance with minimum maintenance. **Follow the coating manufacturer's recommendations when selecting and applying a paint. Refer to the MiraTEC barn trim warranty for long term care and maintenance guidelines of MiraTEC barn trim.**

PAINTING/FINISHING REQUIREMENTS:

MiraTEC barn trim is manufactured from wood and must be painted with an exterior coating system in accordance with the following specifications to fulfill the warranty requirements.

Use a high quality exterior grade acrylic latex paint or oil/alkyd solvent based paint system recommended by the paint manufacturer for application over composite wood substrates. Always follow the paint manufacturer's recommendations for the application and maintenance of field applied paints.

The following topcoats **ARE NOT** recommended by CMI or most paint manufacturers because of short service life, poor protection against UV light, and higher potential for performance problems:

Shake and shingle paints	Vinyl acrylic paint
Flat oil paint	Vinyl acetate paint
Vinyl acetate co-polymer paint	Clear coatings
Transparent or semi-transparent stains	Opaque solvent stains

PAINT APPLICATION:

1. Prime all exposed field-cut edges of MiraTEC barn trim and also topcoat those edges which will be exposed to the weather. Use a high quality exterior primer formulated for use on composite wood. All cut or raw edges should be primed within 30 days of installation.
2. Coat all exposed surfaces including the bottom edge.
3. Finish MiraTEC barn trim with two coats of paint within 90 days of installation. If, due to unforeseen circumstances, the material is not painted within 90 days, reprime the MiraTEC barn trim using an exterior primer that is specifically recommended for use on composite wood products and is compatible with the topcoat to be used. Use the same primer for repair of any damage to the original factory-applied primer.
4. A total field-applied dry film paint thickness of a minimum of 2½ mils is required on MiraTEC barn trim. This requires the application of two or more unthinned coats of paint at the spread rate recommended by the paint manufacturer. **Note: The paint manufacturer may require a primer and topcoat combination. Follow all paint manufacturers' recommendations.**
5. Paint performance can be impacted by ambient temperature and the time of day the paint is applied. Contact the paint manufacturer for specific instructions on applying the coating for maximum results. Most companies can be contacted via a toll free number or website for specific information. Consult your retail store for information.

CMI is not responsible for the performance of field applied finishes. Finish performance is dependent upon coating quality and application methods. These factors are controlled by the finish manufacturer and applicator.

STORAGE:

Cover when stored outside. Keep MiraTEC barn trim off the ground and dry. Excessive moisture pickup from improper storage may affect the performance of MiraTEC barn trim. Do not stack material in excess of 3 units high.

For job site storage, the material should be placed on stringers and covered, preferably on concrete, asphalt, or similar surface. For all other instances, a tarp should be placed over the ground cover under the stringers, with the material still under cover:

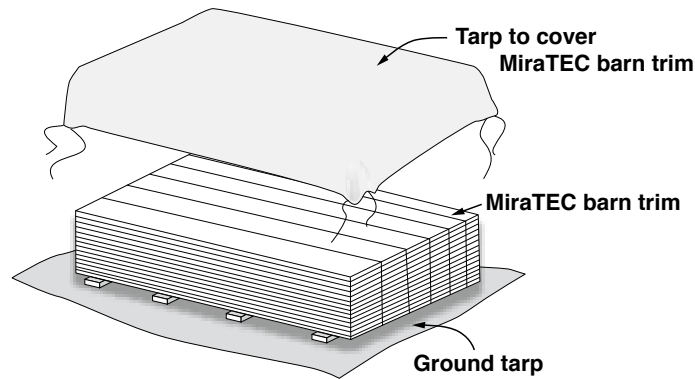

IMPORTANT: Read and understand all application instructions before installing material. The statements expressed in this technical bulletin are the recommendations for the application of the products as outlined and illustrated under normal conditions of installation. CMI is a manufacturer of building materials. It does not practice architecture or engineering. The recommendations provided in this bulletin represent CMI's best judgement based on its experience to date with normal applications. These instructions supplement standard building practices and building code requirements; they are not to be deemed exclusive or exclusionary of these practices and requirements. Unless prior approval is obtained in writing from the Product Performance Department of CMI, PO Box 311, Towanda, PA 18848, any deviation from these recommended procedures shall be at the risk of the installers.

These application instructions are the minimum requirements for the storage, application, and finishing of the trim products manufactured by CMI. Where building code requirements or standards are more restrictive, the applicable regulations must be followed. Consult your local representative or the Product Performance Department for conditions not covered by this bulletin. All drawings are shown for illustration purposes only and are not to scale. Adequate design and bracing of the walls, as well as compliance with these application instructions, are the responsibility of the architect, builder, applicator and painter.